



UNCOMPROMISING QUALITY

GUARANTEED PERFORMANCE

**A COMPLETE LINE OF
MAINTENANCE-FREE BATTERIES FOR AUTOMOTIVE APPLICATIONS**

State-of-the-art engineering and computer-controlled manufacturing techniques combined with more than 250 quality control checks guarantee our batteries deliver more starting power-per-pound.

- ▶ Calcium plate construction eliminates the need to add water, reduces gassing and provides longer shelf life
- ▶ Silver alloy added to battery grids retards the damaging effects of heat for longer service life
- ▶ Flush cover design improves safety and OE fit
- ▶ Premium envelope separator protect plates and prevents premature failure due to life-robbing shorts
- ▶ Computer cast Power Path grids with full frames ensure capacity goes directly to lug for maximum starting power



POW-R-SURGE AUTOMOTIVE BATTERIES

EAST PENN CANADA

A subsidiary of East Penn Manufacturing Co., Inc.

165 Harwood Ave. North, Ajax ON L1Z 1L9

Tel: 905-427-2718 Fax: 905-427-0854

Email: sales@eastpenncanada.com



FEATURES & BENEFITS

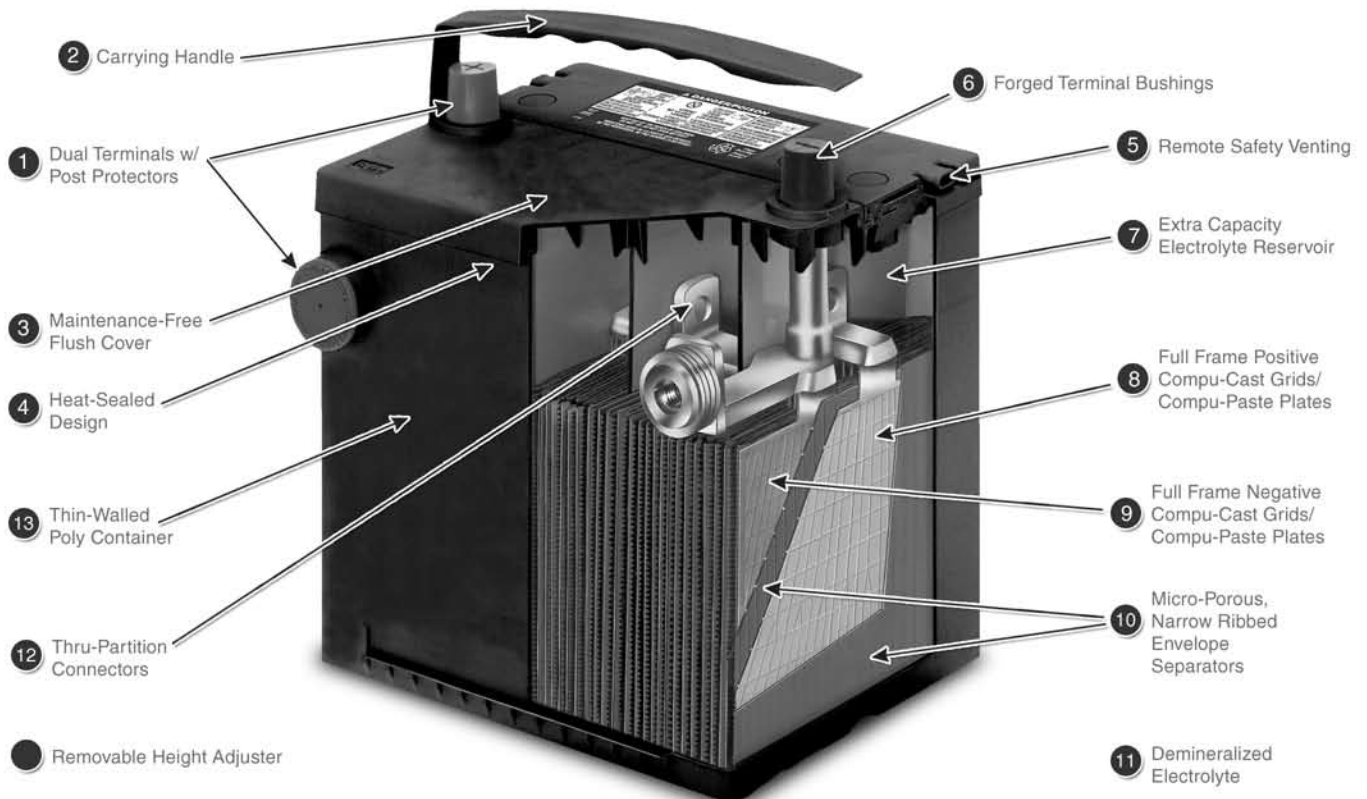

Features and Benefits

- 1 Convenient dual terminal design allows **maximum flexibility** to fit hundreds of different applications.
 - 2 Easy grip carrying handle offers **easy installation**.
 - 3 Original-equipment style flush cover design is truly **maintenance-free**. Fits under O.E. heat shields.
 - 4 High-impact cover is heat sealed to the case under extreme pressure. This helps **prevent electrolyte leakage, improve reliability and reduce breakage**.
 - 5 Remote safety vents are **flame-retardant**. Keeps battery top dry and corrosion-free. Allows remote vent tube installation if required.
 - 6 Forged terminal bushings are fused into the cover to provide maximum **resistance to acid seepage, corrosion and black posts**.
 - 7 Large reservoir above the plates provides ample electrolyte reserve for longer **maintenance-free** performance and life.
 - 8 Positive center-lug, full-frame, power path grids direct more current to the terminals to deliver **maximum starting power** every time. Calcium lead alloy **reduces water loss and self discharge**.
 - 9 Continuous-cast, full-frame, calcium alloy negative grids enhance efficiency of current flow and resist corrosion and vibration damage for **trouble-free service**. There are no sharp grid wires to cause shorts.
 - 10 Premium narrow-rib, deep-pocket envelope separators virtually **eliminate shorting**. Narrow ribs reduce separator corrosion. Deep-pocket envelopes dramatically **improve reliability and extend service life**.
 - 11 Specially formulated electrolyte, an exclusive feature, uses demineralized water for significantly reduced water loss and gassing to **increase maintenance-free life**.
 - 12 Straight-through-the-partition cell connectors shorten current path while **increasing starting power** and delivering **more power-per-pound**.
 - 13 Thin-walled, high-impact polypropylene case **reduces breakage** while creating more room for power-producing plates and acid.
- In addition, a snap-off height adjuster (not pictured) allows installation in short or tall battery applications, for **increased coverage and versatility**.

WEST: 1-800-363-3166 CENTRAL: 1-800-668-9303 EAST: 1-800-361-5935

Copyright 2006 © East Penn Canada Form: A101